

500-EXCELLENT SERIES MODEL GKF 550

**Volume reduction of
glass bottles by 80 %**

A Disperator glass crusher makes light work of handling empty bottles, jars and other glass containers by grinding them to small particles the size of sand. Most kitchens, bars and galleys have problems with the volume of waste.

Collection and transport of waste glass is time consuming because of the large volume. And floor space, which should be put to better use, is occupied with a mountain of empty bottles. These problems are alleviated when a Disperator glass crusher is used.

Model GKF 550 is easy to install in a kitchen, galley or in a garbage room.

Alternatively the glass crusher can be installed on a lower floor level, near to the point of waste collection, and fed with empty bottles by a tube from the bar, kitchen or galley above.

After being ground into small grains of glass with no sharp edges, an empty bottle has only 20% of its original volume which means less storage space, less frequent collection and lower transport costs.

Disperator glass crusher GKF 550 is designed to give long-life in environments where reliability and efficiency are essential.

Further details are specified overleaf.

500-EXCELLENT SERIES MODEL GKF 550

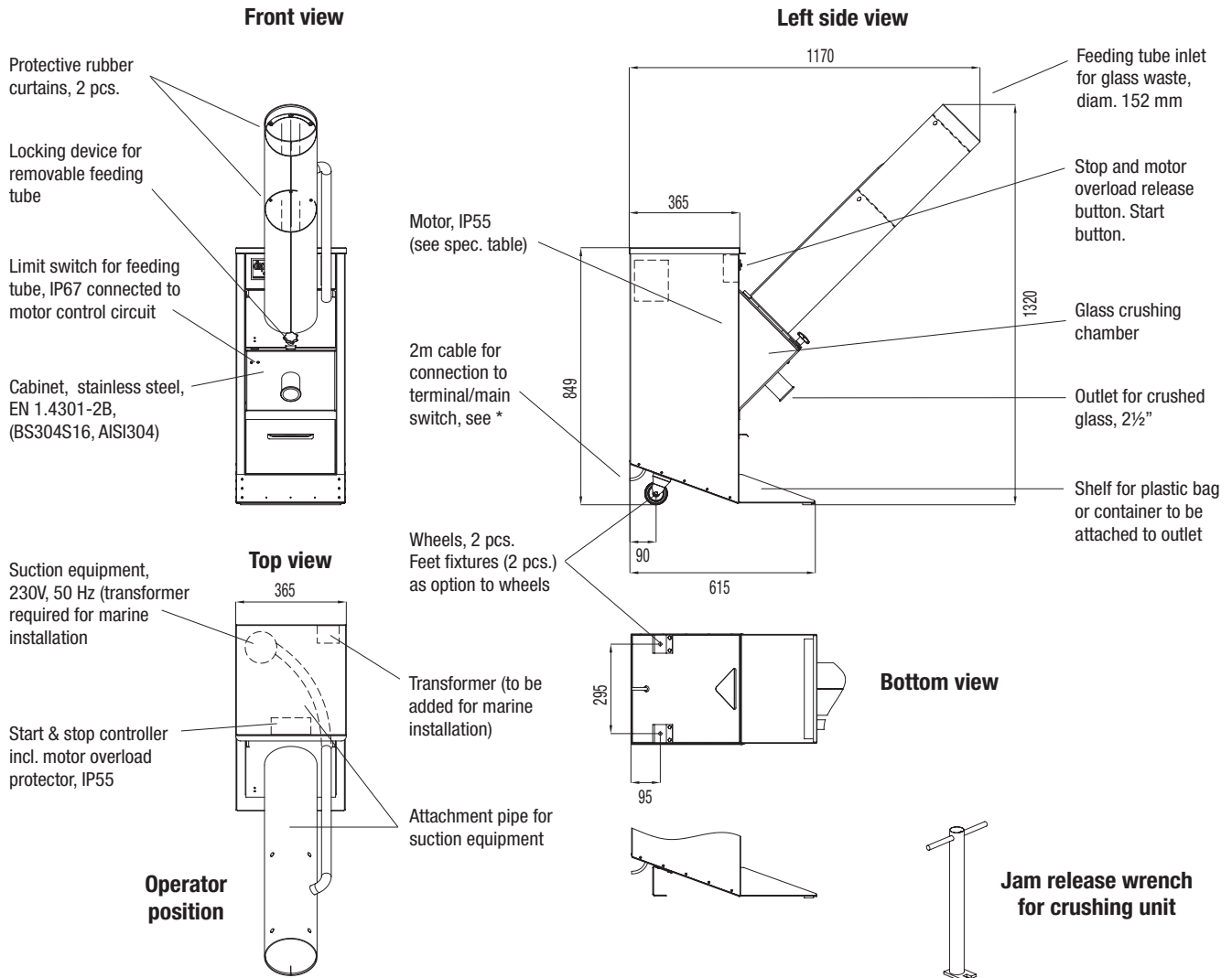

All measurements in mm

Technical Specification	GKF 550
Normal capacity	600-1200 bottles per hour depending on bottle size
Electrical power, kW	1,25
Rated current, A for:	
230V / 3ph / 50Hz	6,4
400V / 3ph / 50Hz	3,7
415V / 3ph / 50Hz	3,7
440V / 3ph / 60Hz	3,2
Other voltages available	
Control voltage	Marine installation the same as motor voltage. Land installation 230V / 50Hz
Fuse rating, slow	16 A
Gross / net weight, kg	138 / 102
Transport volume, m ³	0,9

* Installation material needed but not incl. in standard delivery are terminal or main switch. Can be ordered from DISPERATOR.

** Installation, operation and service instructions are together with this product leaflet included in delivery.

